



ON Semiconductor®

<http://onsemi.com>

LV8121V

Bi-CMOS IC For Fan Motor 3-phase Brushless Motor Driver

Overview

The LV8121V is a three-phase brushless motor driver that uses a PWM drive technique. The motor speed is controlled by changing the PWM duty that based on an analog voltage input. This motor driver includes an automatic return constraint protection circuit and is optimal for driving fan motors.

Features

- PWM control based on an analog voltage input (the CTL voltage), synchronous rectification
- One Hall-effect sensor FG output
- Automatic return constraint protection circuit (ON/OFF=1/15)
- Start/Stop switching circuit, Forward/Reverse switching circuit
- Current limiter circuit, Low-voltage shutdown protection circuit, Thermal shutdown protection circuit

Specifications

Absolute Maximum Ratings at Ta = 25°C

Parameter	Symbol	Conditions	Ratings	Unit
Supply voltage	V _{CC} max	V _{CC} pin	36	V
	V _G max	V _G pin	42	V
Output current	I _O max	t ≤ 500ms	3.5	A
Allowable power dissipation	P _d max	Mounted on a specified board *	1.7	W
Operation temperature	T _{opr}		-30 to +100	°C
Storage temperature	T _{stg}		-55 to +150	°C
Junction temperature	T _j max		150	°C

* Specified board : 114.3mm × 76.1mm × 1.6mm, glass epoxy board

Caution 1) Absolute maximum ratings represent the values which cannot be exceeded for any length of time.

Caution 2) Even when the device is used within the range of absolute maximum ratings, as a result of continuous usage under high temperature, high current, high voltage, or drastic temperature change, the reliability of the IC may be degraded. Please contact us for the further details.

Stresses exceeding Maximum Ratings may damage the device. Maximum Ratings are stress ratings only. Functional operation above the Recommended Operating Conditions is not implied. Extended exposure to stresses above the Recommended Operating Conditions may affect device reliability.

LV8121V

Recommendation Operating Conditions at Ta = 25°C

Parameter	Symbol	Conditions	Ratings	Unit
Supply voltage range	V _{CC}		8.0 to 35	V
5V constant voltage output current	I _{REG}		0 to -6	mA
HB output current	I _{HB}		0 to -7	mA
FG applied voltage	V _{FG}		0 to 6	V
FG output current	I _{FG}		0 to 5	mA

Electrical Characteristics at Ta = 25°C, V_{CC} = 24V

Parameter	Symbol	Conditions	Ratings			Unit
			min	typ	max	
Supply current 1	I _{CC1}			3.5	4.7	mA
Supply current 2	I _{CC2}	At stop		1.1	1.5	mA
Output block						
Lower side output ON resistance	R _{ON(L1)}	I _O = 1.2A		0.26	0.43	Ω
	R _{ON(L2)}	I _O = 2.0A		0.26	0.43	Ω
Upper side output ON resistance	R _{ON(H1)}	I _O = -1.2A		0.27	0.45	Ω
	R _{ON(H2)}	I _O = -2.0A		0.27	0.45	Ω
Mid output current	I _{O(M)}	V _O = 12V		120	170	μA
Lower side diode forward voltage	V _{D(L1)}	I _D = -1.2A		0.9	1.20	V
	V _{D(L2)}	I _D = -2.0A		1.0	1.35	V
Upper side diode forward voltage	V _{D(H1)}	I _D = 1.2A		0.9	1.20	V
	V _{D(H2)}	I _D = 2.0A		1.0	1.35	V
5V Constant voltage Output						
Output voltage	V _{REG}		4.6	5.0	5.4	V
Line regulation	ΔV(REG1)	V _{CC} = 8.0 to 35V		20	100	mV
Load regulation	ΔV(REG2)	I _O = -1 to -6mA		5	100	mV
Hall Amplifier						
Input bias current	I _{B(HA)}		-2	-0.1		μA
Common mode input voltage range 1	V _{ICM1}	When Hall-effect sensors are used	0.3		V _{REG} -1.7	V
Common mode input voltage range 2	V _{ICM2}	When one-side inputs are biased (Hall IC application)	0		V _{REG}	V
Hall input sensitivity	V _{HIN}	SIN wave	80			mVp-p
Hysteresis width	ΔV _{IN(HA)}		9	20	35	mV
Input voltage L → H	V _{SLH}		3	8	16	mV
Input voltage H → L	V _{SHL}		-20	-12	-5	mV
HB pin						
Output voltage	V _{HBO}	I _{HB} = -0.5mA	V _{REG} -0.27	V _{REG} -0.18	V _{REG} -0.10	V
Output leakage current	I _{L(HB)}	V _O = 0V	-10			μA
Reference Oscillator (CT pin)						
High level voltage	V _{H(CT)}		V _{REG} ×0.54	V _{REG} ×0.56	V _{REG} ×0.58	V
Low level voltage	V _{L(CT)}		V _{REG} ×0.43	V _{REG} ×0.45	V _{REG} ×0.47	V
Amplitude	V(CT)		V _{REG} ×0.10	V _{REG} ×0.11	V _{REG} ×0.12	V
Oscillation frequency	f(REF)	C = 56pF, R = 11kΩ	1.71	2.11	2.51	MHz
RT pin						
High level output voltage	V _{OH(RT)}	I _{RT} = -0.3mA	V _{REG} -0.15	V _{REG} -0.1	V _{REG} -0.05	V
Low level output voltage	V _{OL(RT)}	I _{RT} = 0.3mA	0.05	0.1	0.15	V
Charge Pump Output (VG pin)						
Output voltage	V _{GOUT}		V _{CC} +4.1	V _{CC} +4.7	V _{CC} +5.4	V
CP1 pin						
High level output voltage	V _{OH(CP1)}	I _{CP1} = -2mA	V _{CC} -1.4	V _{CC} -1.1	V _{CC} -0.7	V
Low level output voltage	V _{OL(CP1)}	I _{CP1} = 2mA	0.55	0.75	0.90	V
Charge pump frequency	f(CP1)			f(REF)/32		MHz

Continued on next page.

LV8121V

Continued from preceding page.

Parameter	Symbol	Conditions	Ratings			Unit
			min	typ	max	
PWM Oscillator						
High level voltage	$V_H(\text{PWM})$		2.75	3.05	3.35	V
Low level voltage	$V_L(\text{PWM})$		1.20	1.35	1.50	V
Amplitude	$V(\text{PWM})$		1.40	1.70	2.00	V
Charge current	I_{CHG}	$V_{\text{PWM}} = 2.1\text{V}$	-80	-63	-45	μA
Oscillation frequency	$f(\text{PWM})$	$C = 1800\text{pF}$	15.1	19.2	24.8	kHz
LIM pin						
Input bias current	$I_B(\text{LIM})$		-2	-0.1		μA
CTL pin						
Input voltage	V_{CTL1}	Output duty: 100%	2.74	3.07	3.40	V
	V_{CTL2}	Output duty: 0%	1.15	1.33	1.51	V
Input bias current	$I_B(\text{CTL})$		-2	-0.2		μA
Current limiter operation						
Limiter voltage	V_{RF}		0.23	0.25	0.275	V
CSD Oscillator						
High level voltage	$V_H(\text{CSD})$		2.75	3.05	3.35	V
Low level voltage	$V_L(\text{CSD})$		1.43	1.68	1.93	V
Amplitude	$V(\text{CSD})$		1.12	1.37	1.62	V
Charge current	I_{CSD1}		-13.5	-10.5	-7.0	μA
Discharge current	I_{CSD2}		8.0	11.5	14.5	μA
Oscillation frequency	$f(\text{CSD})$	$C = 0.047\mu\text{F}$	62	83	104	Hz
Thermal shutdown operation						
Thermal shutdown operation temperature	TSD	Design target value * (Junction temperature)	150	180		$^{\circ}\text{C}$
Hysteresis width	ΔTSD	Design target value * (Junction temperature)		40		$^{\circ}\text{C}$
FG pin						
Low level output voltage	$V_{\text{OL}}(\text{FG})$	$I_{\text{FG}} = 2\text{mA}$		0.1	0.3	V
Output leakage current	$I_L(\text{FG})$	$V_{\text{FG}} = 6\text{V}$			10	μA
Low-voltage shutdown protection circuit						
Operating voltage	V_{SDL}		6.52	7.03	7.54	V
Release voltage	V_{SDH}		6.98	7.49	8.00	V
Hysteresis width	ΔVSD		0.36	0.46	0.56	V
F/R pin						
High level input voltage range	$V_{\text{IH}}(\text{FR})$		2.0		VREG	V
Low level input voltage range	$V_{\text{IL}}(\text{FR})$		0		1.0	V
Input open voltage	$V_{\text{IO}}(\text{FR})$		VREG-0.5		VREG	V
Hysteresis width	$V_{\text{IS}}(\text{FR})$		0.15	0.35	0.5	V
High level input current	$I_{\text{IH}}(\text{FR})$	$V_{\text{F/R}} = \text{VREG}$	-10	0	10	μA
Low level input current	$I_{\text{IL}}(\text{FR})$	$V_{\text{F/R}} = 0\text{V}$	-80	-50	-35	μA
S/S pin						
High level input voltage range	$V_{\text{IH}}(\text{SS})$		2.0		VREG	V
Low level input voltage range	$V_{\text{IL}}(\text{SS})$		0		1.0	V
Input open voltage	$V_{\text{IO}}(\text{SS})$		VREG-0.5		VREG	V
Hysteresis width	$V_{\text{IS}}(\text{SS})$		0.15	0.35	0.5	V
High level input current	$I_{\text{IH}}(\text{SS})$	$V_{\text{S/S}} = \text{VREG}$	-10	0	10	μA
Low level input current	$I_{\text{IL}}(\text{SS})$	$V_{\text{S/S}} = 0\text{V}$	-80	-50	-35	μA

* : These items are design target value and are not tested.

LV8121V

Package Dimensions

unit : mm (typ)
3333A

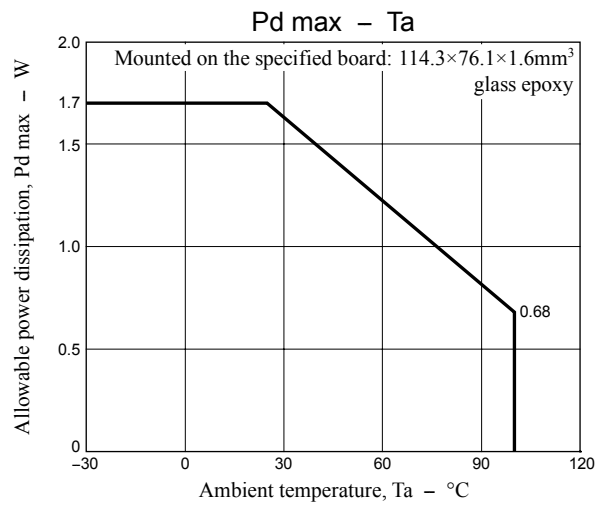
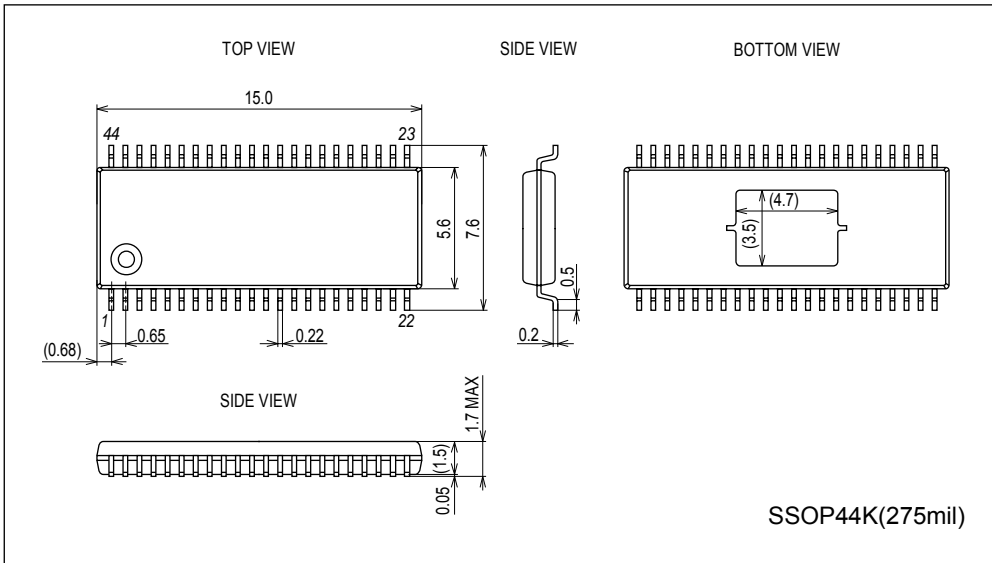

Pin Assignment

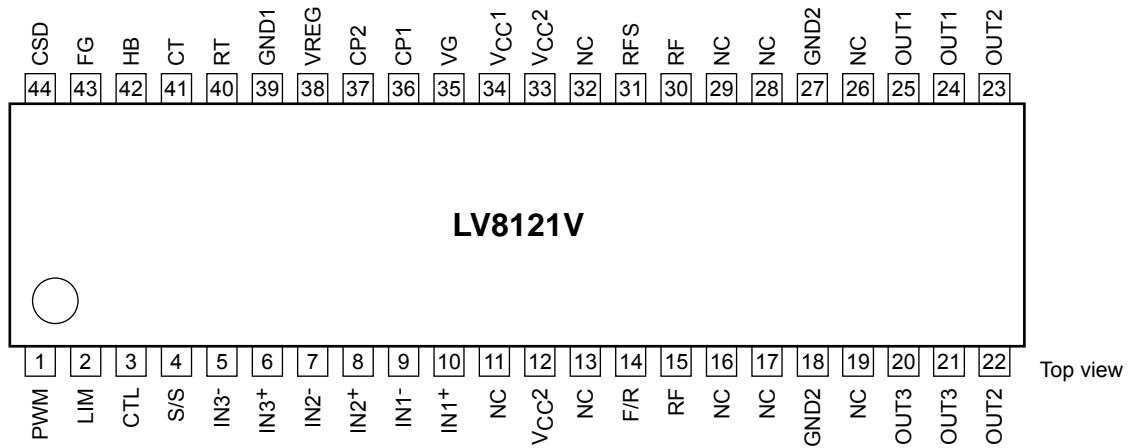

Block Diagram

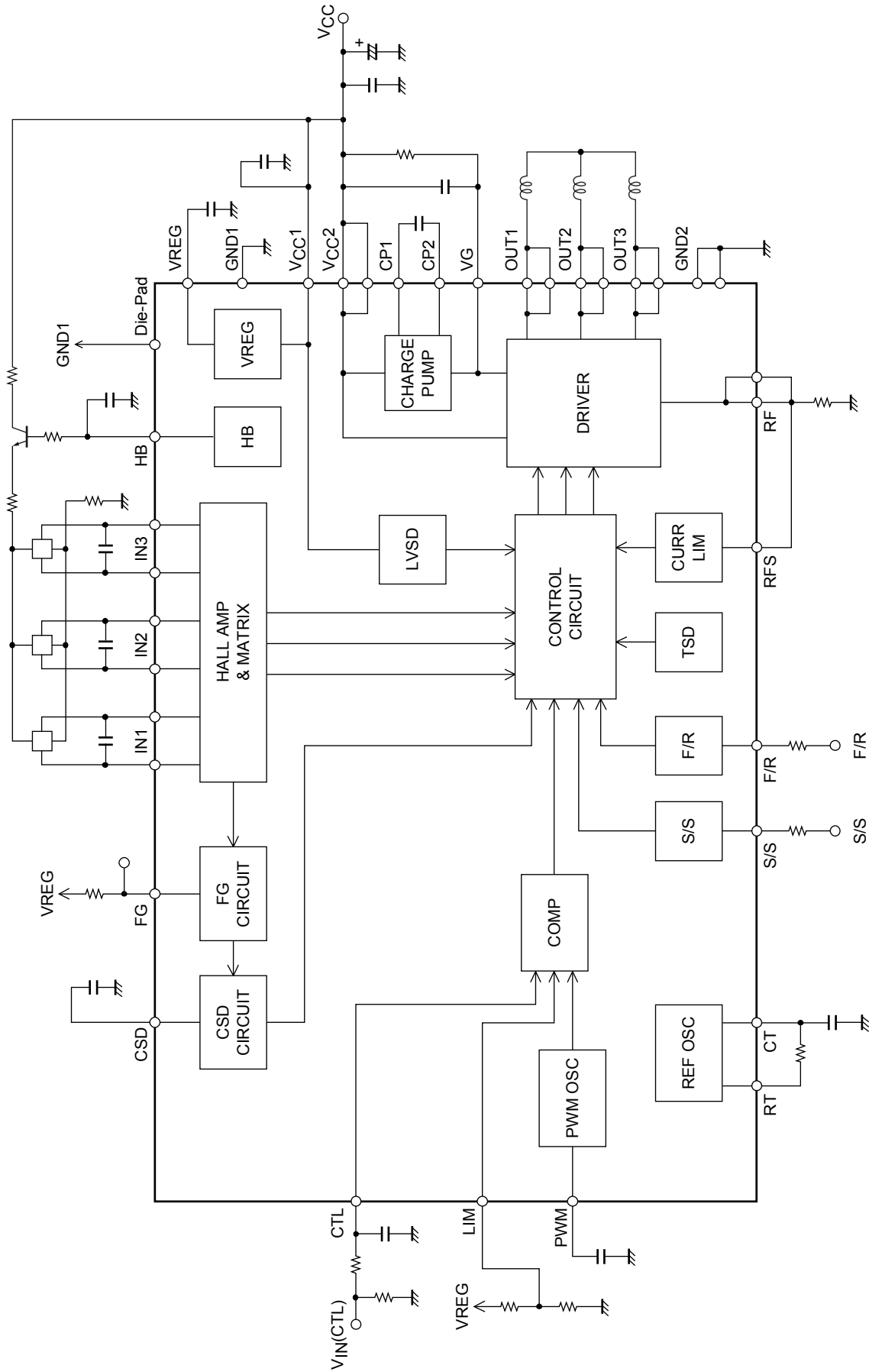

LV8121V

Pin Function

Pin No.	Pin name	Function	Equivalent circuit
1	PWM	Pin to set the PWM oscillation frequency. Connect a capacitor between this pin and GND1. A frequency of about 19kHz can be set by using a 1800pF capacitor.	
2	LIM	Pin to set the minimum output duty. A minimum output duty can be set by inputting a fixed voltage to the LIM pin through resistor division of VREG. Connect the LIM pin to GND1 if this pin is not used, then the minimum output duty becomes 0 %.	
3	CTL	Pin to control the output duty. The output duty is determined by the result of comparing the CTL pin voltage with the PWM oscillation waveform. When the CTL pin is open, the output duty becomes 100%. Therefore, connect a pull-down resistor to prevent open.	
4	S/S	Start / Stop control pin. Low : 0V to 1.0V High : 2.0V to VREG Goes high when left open. Low for start. The hysteresis width is about 0.35V.	
5 6 7 8 9 10	IN3 ⁻ IN3 ⁺ IN2 ⁻ IN2 ⁺ IN1 ⁻ IN1 ⁺	Hall input pins. The input is seen as the high level input when IN ⁺ > IN ⁻ , and as the low level input for the opposite state. If noise on the Hall signals is a problem, connect a capacitor between the corresponding IN ⁺ and IN ⁻ inputs.	

Continued on next page.

LV8121V

Continued from preceding page.

Pin No.	Pin name	Function	Equivalent circuit
14	F/R	Forward / Reverse control pin. Low : 0V to 1.0V High : 2.0V to VREG Goes high when left open. Low for forward. The hysteresis width is about 0.35V.	
34	V _{CC1}	Power supply pin. (For systems other than the motor drive output.) Connect a capacitor between this pin and GND1 for stabilization.	
12, 33	V _{CC2}	Motor drive output power supply pins.	
20, 21 22, 23 24, 25	OUT3 OUT2 OUT1	Motor drive output pins.	
15, 30	RF	Source pins of the lower side output FET. Connect a resistor (Rf) between these pins and GND.	
18, 27	GND2	Motor drive output circuit GND pins.	
31	RFS	Output current detection pin. Connect the RFS pin to the RF pin.	
35	VG	Charge pump output pin. Connect a capacitor between this pin and V _{CC2} .	
37	CP2	Pin to connect the capacitor for charge pump. Connect a capacitor between this pin and CP1.	

Continued on next page.

LV8121V

Continued from preceding page.

Pin No.	Pin name	Function	Equivalent circuit
36	CP1	Pin to connect the capacitor for charge pump. Connect a capacitor between this pin and CP2.	
38	VREG	5V constant voltage output pin. (Power supply pin for the control circuits.) Connect a capacitor between this pin and GND1 for stabilization.	
39	GND1	GND pin for the control circuits.	
40	RT	Pin to set the reference oscillation frequency. Connect a resistor to charge / discharge the capacitor of CT between this pin and CT.	
41	CT	Pin to set the reference oscillation frequency. Connect a capacitor between this pin and GND1.	
42	HB	Hall bias switch pin. Goes off when the S/S input is the stop mode.	
43	FG	One hall-effect sensor FG output pin. (This is an open-drain output.)	

Continued on next page.

LV8121V

Continued from preceding page.

Pin No.	Pin name	Function	Equivalent circuit
44	CSD	Pin to set the operating time of the constraint protection. Connect a capacitor between this pin and GND1.	
11, 13 16, 17 19, 26 28, 29 32	NC	No connection pins.	
Backside metal	Die-Pad	Exposed Die-Pad. The metal of the IC's backside is the Exposed Die-pad and is internally connected to GND1, GND2. For stabilization, connect the Exposed Die-pad to GND1 externally.	

Three-phase logic truth table (A high level input is the state where $IN^+ > IN^-$)

	F/R = L			F/R = H			Output		
	IN1	IN2	IN3	IN1	IN2	IN3	OUT1	OUT2	OUT3
1	H	L	H	L	H	L	L	H	M
2	H	L	L	L	H	H	L	M	H
3	H	H	L	L	L	H	M	L	H
4	L	H	L	H	L	H	H	L	M
5	L	H	H	H	L	L	H	M	L
6	L	L	H	H	H	L	M	H	L

Description of LV8121V

1. Motor Drive Output Circuit

The LV8121V provides a charge pump circuit and implements both upper side and lower side N-channel power FET drive circuit. This IC employs the direct PWM drive technique. The motor speed is controlled by changing the output duty according to an analog voltage input (CTL). The upper side N-channel power FET is switched so that the output duty tracks the CTL voltage.

The PWM frequency is determined by the capacitor connected between the PWM pin and GND1.

When the PWM switching of the upper side N-channel power FET is off, the lower side N-channel power FET is turned on (synchronous rectification). Therefore, it is possible to reduce the temperature increase of the lower side N-channel power FET.

2. PWM Oscillator

The PWM frequency is set by the oscillation frequency of the PWM pin. When a capacitor C [F] is connected between the PWM pin and GND1, the PWM frequency (fPWM) is calculated as follows.

$$f_{\text{PWM}} = 1/(28900 \times C)$$

When a 1800pF capacitor is connected, this frequency becomes about 19kHz.

By the variance of the IC, “28900” of the above formula has varied from 22400 to 36800.

If the PWM frequency is too high, since the switching power loss will be large, the IC temperature increase will be excessive. The PWM frequency therefore should be normally kept below 50kHz, which is achieved with a capacitor C of 1000pF or higher. The GND lead of the connected capacitor to the PWM pin should be connected as close as possible to the GND1 pin.

3. Output Duty

The CTL voltage and the PWM oscillation waveform are compared to determine the output duty of the upper side N-channel power FET.

If the LIM pin is not used (LIM=GND), the output duty becomes 0% when the CTL voltage is lower than about 1.3V and 100% when it exceeds about 3.1V.

For the application that inputs a fixed voltage to the LIM pin, the LIM voltage and the PWM oscillation waveform are compared to determine the minimum output duty. Accordingly, even if the CTL voltage is lower than the LIM voltage, the output duty does not decrease below the minimum output duty.

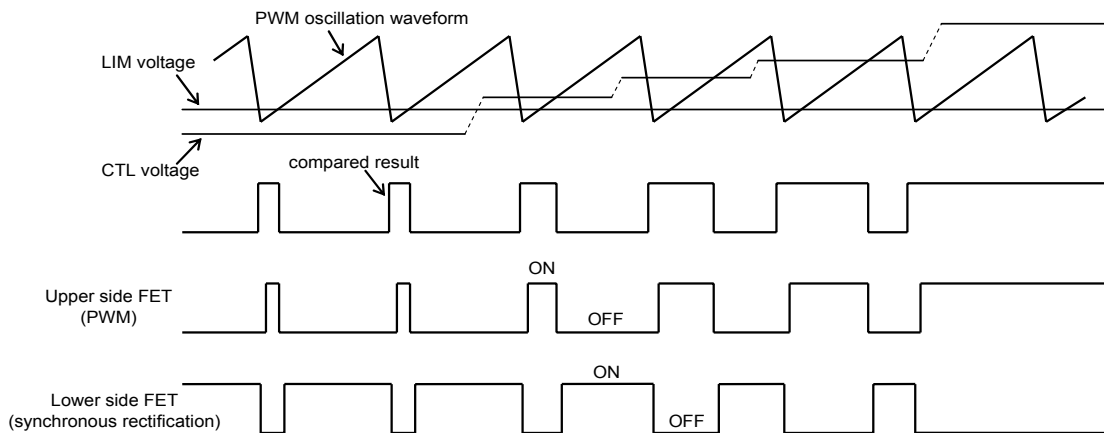

If a minus voltage is applied to the CTL pin, this pin current must be limited within 2mA by inserting the resistor of about 200Ω.

When the CTL pin is open, the output duty becomes 100%. Therefore, connect a pull-down resistor to prevent open. If the output duty is fast reduced by dropping the CTL voltage quickly when the motor speed is changed from high to low, since this IC employs the synchronous rectification, the lower side N-channel power FET can be the short brake condition that turns on two phases. If the lower side N-channel power FET (synchronous rectification) is switched from on to off while this condition, the motor current may flow on the power supply side, and the power supply voltage may bounce. The bounce of the power supply voltage is different on the motor speed, the varied range of the CTL voltage and the capacitance of the power supply line. Therefore, check sufficiently that the bounce of the power supply voltage does not exceed the maximum rating when the CTL voltage is changed.

Continued on next page.

Continued from preceding page.

In case of limiting the bounce of the power supply voltage, the maximum voltage of the V_{CC} can be limited according to the following method. The maximum voltage of the VG is limited by using Zener diode, NPN transistor and some resistors. Normally, the relation between VG and V_{CC} becomes " $VG = V_{CC} + 4.7V$ ". If V_{CC} rises above " $VG_{max} - 4.7V$ " when VG is limited to VG max, this relation does not keep.

Because the sufficient gate voltage cannot be applied to the upper side N-channel power FET when this relation does not keep, this IC includes the protective function that turns off the upper side N-channel power FET.

Accordingly, if V_{CC} rises above " $VG_{max} - 4.7V$ " when VG is limited to VG max, the upper side N-channel power FET is turned off, and the V_{CC} bounce caused by dropping the CTL voltage can be limited to " $V_{CC} = VG_{max} - 4.7V$ ". When the above reference circuit is used, VG is limited to about 36.7V, and V_{CC} is limited to about 32.0V. But this function does not guarantee that any V_{CC} bounce can be limited. If V_{CC} is steeply bounced by dropping the CTL voltage, this function may not limit the V_{CC} bounce.

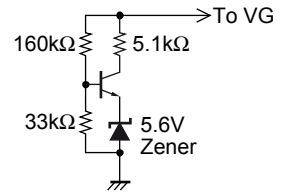

4. Current Limiter Circuit

The current limiter circuit limits the output current peak to the value determined by " $I = V_{RF}/R_f$ " ($V_{RF} = 0.25V$ typ., R_f : current detection resistor). When the current limiter is operating, the upper side N-channel power FET is switched, and the output current is suppressed by reducing the output duty.

5. Reference Oscillator

Connect a 56pF capacitor between CT and GND1, and a 11kΩ resistor between RT and CT. Then, the reference oscillation frequency becomes about 2.1MHz. The reference oscillation frequency functions as a reference clock for the internal logic circuit. The charge pump circuit boosts the voltage using a frequency that is 1/32 of the reference oscillation frequency.

6. Start/Stop Switching Circuit

When the S/S pin is set to the low level, start/stop switching circuit is the start mode. Inversely, when the S/S pin is set to the high level or open, start/stop switching circuit is the stop mode. This IC goes into a power saving state that reduces the supply current at the stop mode. In the power saving state, the bias current is removed from most of the circuits in the IC.

The operating circuits in the power saving state are limited to the start/stop switching circuit and the 5V constant voltage output. The other circuits do not operate. Both upper side and lower side N-channel power FET are turned off in the power saving state.

If a minus voltage is applied to the S/S pin, this pin current must be limited within 2mA by inserting the resistor of about 200Ω.

7. Forward / Reverse Switching Circuit

The motor rotation direction can be switched by using the F/R pin. However, the following notes must be observed if the F/R pin is switched while the motor is rotating.

- This IC is designed to avoid the through current when the direction is switched. However, the bounce of the V_{CC} voltage (due to the motor current that flows instantly on the power supply side) may be caused during the direction switching. If this bounce is a problem, the capacitance inserted between V_{CC} and GND must be increased.
- If the motor current after the direction switching exceeds the current limiter value, the upper side N-channel power FET will be turned off, but the lower side N-channel power FET will be the short brake condition. On the short brake condition, the current determined by the motor back EMF voltage and the coil resistance will flow. Because the current limiter circuit of this IC cannot limit this current, applications must be designed so that this current does not exceed the maximum rating (3.5A). When the motor speed is higher, the direction switching is dangerous.

If a minus voltage is applied to the F/R pin, this pin current must be limited within 2mA by inserting the resistor of about 200Ω.

8. Hall Input Signal

The input amplitude of 100mVp-p or more (differential) is desirable in the Hall inputs. The closer the input wave-form is to a square wave, the required input amplitude is lower. Inversely, the closer the input wave-form is to a triangular wave, the higher input amplitude is required. Also, note that the input DC voltage must be set within the common mode input voltage range.

For the Hall IC application, one side (either the + or – side) of the Hall inputs must be fixed at a voltage within the common mode input voltage range that applies when the Hall-effect sensors are used, and the input voltage range for the other side becomes 0V to VREG.

If noise on the Hall signals is a problem, that noise must be excluded by inserting capacitor between the Hall inputs as close as possible to these pins.

When the Hall inputs for all three phases are in the same state, all the outputs (the both upper side and lower side N-channel power FET) are turned off.

9. FG Output

The FG pin is the pulse output that has the same frequency as Hall input IN1 (one Hall-effect sensor FG output).

10. HB Pin

The HB pin is the 5V constant voltage output that combines the switch function. This pin is connected to the base of external NPN transistor that supplies the bias of the Hall-effect sensors. If the HB output is turned off, this external NPN transistor is too turned off, and the bias of the Hall-effect sensors is cut (Hall bias switch).

The HB output is turned off and is made pull-down by a 100kΩ internal resistor when the S/S pin is the stop mode. Therefore, the bias of the Hall-effect sensors can be cut when the S/S pin is the stop mode.

In case the LIM pin is not used (LIM = GND), if the CTL voltage falls below 0.7V, the HB output is turned off, and the bias of the Hall-effect sensors is cut.

In case the minimum output duty is determined by the LIM pin, even if the CTL voltage falls below 0.7V, the HB output is not turned off.

If the HB pin is not used, keep open.

11. Constraint Protection Circuit

The constraint protection circuit operates to turn the motor drive (the upper side N-channel power FET) on or off repeatedly in the motor constrained state. Therefore, the IC and the motor are protected. The drive on/off time can be set by adjusting the oscillation frequency of the CSD pin with external capacitor. When a capacitor C [μF] is connected between the CSD pin and GND1, the drive on/off time is calculated as follows.

$$T_{CSD1} (\text{drive on time}) = 8.21 \times C$$

$$T_{CSD2} (\text{drive off time}) = T_{CSD1} \times 15$$

When a 0.047μF capacitor is connected, this protection function will iterate an on/off period in which drive is on for about 0.39sec and off for about 5.8sec.

By the variance of the IC, “8.21” of the above formula has varied from 5.41 to 11.01.

If the switching from L to H of the Hall input IN1 (the rising edge on the FG output) is not caused during the drive on time, this protection function turns the motor drive off, and returns the motor drive on after the drive off time.

If the drive on time to be set is too short, this protection function operates at a normal motor start-up, and the motor may not speed up since this protection function iterates an on/off period. Also, if the motor speed is too low, this protection function operates when one cycle of the Hall input IN1 is longer than the drive on time. The drive on time must be set to a sufficient time so that this protection function does not operate except the motor constrained state.

The oscillation waveform of the CSD pin is used for some circuits in addition to the constraint protection circuit.

Therefore, it is desirable to oscillate the CSD pin even if the constraint protection function is unnecessary.

The CSD pin combines the function as the initial reset pin. The time that the CSD voltage is charged to about 1.25V is determined as the initial reset. At the initial reset, all the outputs (the both upper side and lower side N-channel power FET) are turned off.

If the constraint protection function is not used, the oscillation of the CSD pin must be stopped by connecting a 220kΩ resistor and a 0.01μF capacitor in parallel between the CSD pin and GND1. However, when the oscillation of the CSD pin is stopped, note that some functions do not operate in the following cases.

- If the motor does not rotate at the motor start-up because the motor is constrained, the upper side N-channel power FET may be switched by the current limiter. But, the synchronous rectification does not operate when the oscillation of the CSD pin is stopped. Continued on next page.
- In case the LIM pin is not used (LIM = GND), even if the CTL voltage falls below 0.7V, the HB output is not turned off when the oscillation of the CSD pin is stopped.

12. Low-voltage Shutdown Protection Circuit

The IC includes a low-voltage shutdown protection circuit to protect against incorrect operation when the V_{CC} power supply is switched on or if the V_{CC} voltage falls below the allowable operating range. When the V_{CC} voltage falls below the specified voltage (VSDL), this protection function operates, and all the outputs (the both upper side and lower side N-channel power FET) are turned off. When the V_{CC} voltage rises above the release voltage (VSDH), this protection function is released.

13. Thermal Shutdown Protection Circuit

If the junction temperature rises to the specified temperature (TSD), this protection function operates, and the upper side N-channel power FET is turned off. If the temperature decrease falls to more than the hysteresis width (ΔTSD), this protection function is released.

14. Power Supply Stabilization

Because a large switching current flows in the V_{CC} line, the line inductance and other factors can lead to V_{CC} voltage fluctuations. Sufficient capacitance should be provided between V_{CC} and GND for stabilization. When long wiring routes are used, choose a capacitor with even larger capacitance.

Ceramic capacitors of about $0.2\mu\text{F}$ must be connected between the V_{CC1} pin and the GND1 pin as close as possible to these pins for excluding noise.

15. VREG Pin

The VREG pin is the power supply for the control circuits. Therefore, a capacitor of about $0.1\mu\text{F}$ must be connected between the VREG pin and the GND1 pin as close as possible to these pins for stabilization.

16. VG Pin

When the S/S pin is the stop mode, the VG pin is the high-impedance condition in the IC. If the ambient temperature of the capacitor inserted between VG and V_{CC2} becomes high when the VG pin is the high-impedance condition, since the voltage charged in this capacitor may rise due to the temperature characteristic of the capacitor, the VG voltage may rise. Therefore, prevent the VG voltage from rising by inserting the resistor of about $200\text{k}\Omega$ between VG and V_{CC2} or VG and GND1 so that the VG pin is not the high-impedance condition.

17. Notes on wiring of a Printed Circuit Board

Two pins are provided for each of pins (V_{CC2} , RF, OUT1, OUT2, OUT3, GND2) where large current flows. Both of these pins should be externally connected.

18. The Metal of the IC's Backside

The metal of the IC's backside is the Exposed Die-pad and is internally connected to GND1, GND2. For stabilization, connect the Exposed Die-pad to GND1 externally. The IC's generation of heat can be efficiently diffused to a printed circuit board by soldering the Exposed Die-pad to the copper of the printed circuit board.

19. NC Pins

The NC pins are electrically open. These pins may be used for wiring routes.

Mouser Electronics

Authorized Distributor

Click to View Pricing, Inventory, Delivery & Lifecycle Information:

[onsemi:](#)

[LV8121V-TLM-H](#)